

## 26 Safety Belt

Refer to: R16 06-R6/C1

### 26.1 Effective Date and Scope:

- 26.1.1 Effective date from 2006/7/1, the new vehicle of category symbols M and N, and from 2008/7/1 all vehicle variants of category symbols M and N, shall comply with this regulation.
- 26.1.2 The applicants applying for low volume safety approval or vehicle-by-vehicle low volume safety approval could exempt from regulation of "safety belt" except large passenger vehicle and child-only vehicle.

### 26.2 Definitions:

- 26.2.1 Safety-belt: An arrangement of straps with a securing buckle, adjusting devices and attachments which is capable of being anchored to the interior of a power-driven vehicle and is designed to diminish the risk of injury to its wearer, in the event of collision or of abrupt deceleration of the vehicle, by limiting the mobility of the wearer's body.
- 26.2.2 Strap: A flexible component designed to hold the body and to transmit stresses to the belt anchorages.
- 26.2.3 Retractor: Device to accommodate part or the whole of the strap of a safety-belt.
- 26.2.4 Emergency locking retractor (type 4): A retractor which during normal driving conditions does not restrict the freedom of movement by the wearer of the safety-belt. Such a device has length adjusting components which automatically adjust the strap to the wearer and a locking mechanism actuated in an emergency by: deceleration of the vehicle, or a combination of deceleration of the vehicle, movement of the webbing or any other automatic means.
- 26.2.5 Emergency locking retractor with higher response threshold: A retractor of the type of Emergency locking retractor, but having special properties as regards its use in vehicles of category symbols M2, M3, N1, N2 and N3.
- 26.2.6 Automatically locking retractor: A retractor allowing extraction of the strap to the desired length and which, when the buckle is fastened, automatically adjusts the strap to the wearer. Further extraction of the strap is prevented without voluntary intervention by the wearer.

### 26.3 Safety Belt shall according to suitable types and range of principle are as below :

- 26.3.1 Trade name
- 26.3.2 Rigid parts (buckle, attachments, retractor, etc.)
- 26.3.3 The material, weave, dimensions of the straps
- 26.3.4 The geometry of the belt assembly

### 26.4 Test methods:

#### 26.4.1 Corrosion test:

A complete safety-belt assembly shall be positioned in a test chamber. In the case of an assembly incorporating a retractor, the

The official directions are written in Chinese, this English edition is for your reference only.

strap shall be unwound to full length less  $300 \pm 3$  mm. The exposure test shall proceed continuously for a period of 50 hours. On completion of the exposure test the assembly shall be gently washed, or dipped in clean running water with a temperature not higher than  $38 \text{ }^{\circ}\text{C}$  to remove any salt deposit that may have formed and then allowed to dry at room temperature for 24 hours before inspection

26.4.2 Micro-slip test:

26.4.2.1 The samples to be submitted to the micro-slip test shall be kept for a minimum of 24 hours in an atmosphere having a temperature of  $20 \pm 5$  degrees C and a relative humidity of  $65 \pm 5$  per cent. The test shall be carried out at a temperature between 15 and 30 degrees C.

26.4.2.2 1,000 cycles shall be completed at a frequency of 0.5 cycles per second, the total amplitude being  $300 \pm 20$  mm (see Fig 5). The 50 N load shall be applied only during the time corresponding to a shift of  $100 \pm 20$  mm for each half period.

26.4.3 Strap test: The test shall be carried out each time on two new samples of strap, of sufficient length.

26.4.3.1 The initial breaking strength test: The strap shall be conditioned in accordance with ISO 139 (2005) in the standard atmosphere or the standard alternative atmosphere for at least 24 hours. If the test is not carried out immediately after conditioning, the specimen shall be placed in a hermetically-closed receptacle until the test begins. The breaking load shall be determined within five minutes after removal of the strap from the conditioning atmosphere or from the receptacle. The speed of traverse shall be about 100 mm/min.

26.4.3.2 Width test:

26.4.3.2.1 The test shall be carried out each time on two new samples of strap, of sufficient length and conditioned in conformity with the provisions of paragraph 26.4.3.1.

26.4.3.2.2 Each strap shall be gripped between the clamps of a tensile-testing machine. The clamps shall be so designed as to avoid breaking of the strap at or near them. The speed of traverse shall be about 100 mm/min. The free length of the specimen between the clamps of the machine at the start of the test shall be  $200 \text{ mm} \pm 40 \text{ mm}$ .

26.4.3.2.3 When the load reaches  $9800 \text{ N} + 1000 - 0 \text{ N}$ , the machine shall be stopped and the measurement shall be completed within 5 seconds. The test has to be performed separately from the tensile test.

26.4.3.3 Light-conditioning test:

26.4.3.3.1 The strap shall be exposed to light for the time necessary to produce a contrast equal to grade 4 on the grey scale on Standard Blue Dye No. 7.

26.4.3.3.2 After exposure the strap shall be conditioned as described under paragraph 26.4.3.1. If the test is not carried out immediately after conditioning the specimen shall be placed in a hermetically-closed receptacle until the test begins. The breaking load shall

be determined within five minutes after removal of the strap from the conditioning installation. The speed of traverse shall be about 100 mm/min.

26.4.3.4 Abrasion conditioning test: The samples shall be conditioned as described under paragraph 26.4.3.1. kept for a minimum of 24 hours. The ambient temperature during the abrasion procedure shall be between 15 and 30 degrees C.

Particular Conditioning Procedures	Load (N)	Frequency (Hz)	Cycles Numbers	Shift (mm)
For cases where the strap slides through an adjusting device. (see Fig 3)	25	0.5	5000	300+/-20
For cases where the strap changes direction in passing through a rigid part. (see Fig 4)	5	0.5	45000	300+/-20
For cases where the strap is fixed to a rigid part by sewing or similar means. (see Fig 5)	0~50	0.5	45000	--

notes : In the table above are listed the general conditions for each abrasion procedure , after buckle-opening test , if slide quantity is lower than 1/2 of 26.5.2 stipulation , it can exempt strap slides through an adjusting device of procedures .

26.4.3.5 Cold conditioning test: The strap shall be conditioned as described under paragraph 26.4.3.1. kept for a minimum of 24 hours. The strap shall then be kept for one and a half hours on a plane surface in a low-temperature chamber in which the air temperature is  $-30 \pm 5$  degrees C. It shall then be folded and the fold shall be loaded with a mass of 2 kg previously cooled to  $-30 \pm 5$  degrees C. When the strap has been kept under load for 30 minutes in the same low-temperature chamber, the mass shall be removed and the breaking load shall be measured within 5 minutes after removal of the strap from the low-temperature chamber. The speed of traverse shall be about 100 mm/min.

26.4.3.6 Heat conditioning test: The strap shall be kept for three hours in a heating cabinet in an atmosphere having a temperature of  $60 \pm 5$  degrees C and a relative humidity of  $65 \pm 5$  per cent. The breaking load shall be determined within five minutes after removal of the strap from the heating cabinet. The speed of traverse shall be about 100 mm/min.

26.4.3.7 Exposure-to-water test: The strap shall be kept fully immersed for three hours in distilled water, at a temperature of  $20 \pm 5$  degrees C, to which a trace of a wetting agent has been added. Any wetting agent suitable for the fiber under test may be used. The breaking load shall be determined within 10 minutes after removal of the strap from the water. The speed of

traverse shall be about 100 mm/min.

#### 26.4.4 Test of belt assembly components incorporating rigid parts:

##### 26.4.4.1 Strength test:

26.4.4.1.1 The buckle and the adjusting device shall be connected to the tensile-testing apparatus by the parts of the belt assembly to which they are normally attached, and the load shall then build up to 9800 N. The attachments and any belt adjustment devices for height shall be tested in the same manner, but the load shall be 14,700 N and shall be applied in the least favourable conditions likely to occur in a vehicle in which the belt is correctly installed.

26.4.4.1.2 Buckles having parts common to two safety-belts shall be loaded in such a way as to simulate the conditions of use in the vehicle with seats in the mid position of their adjustment. A load of 14,700 N shall be applied simultaneously to each strap, see Fig 6.

##### 26.4.4.2 Operation-force test:

When testing a manually adjusting device, the strap shall be drawn steadily through the adjusting device, having regard for the normal conditions of use, at a rate of approximately 100 mm/s and the maximum force after 25 mm of strap movement.

#### 26.4.5 Buckle test:

26.4.5.1 Durability test: The buckle shall be capable of withstanding repeated operation and shall undergo 5,000 opening and closing cycles under normal conditions of use.

26.4.5.2 Buckle-opening test: when it is not under tension and when under the tension specified in dynamic test below, it shall be capable of being released by the wearer with a single simple movement of one hand in one direction; A load shall be applied at a speed of 400 +/- 20 mm/min to the geometric centre of the buckle-release button along a fixed axis running parallel to the initial direction of motion of the button. Before the dynamic test, the tension is zero, but after it the tension is 600/n (It is understood that n is the number of straps linked to the buckle when it is in a locked position.).

#### 26.4.6 Tests for safety-belt with retractors:

##### 26.4.6.1 The emergency locking retractors:

26.4.6.1.1 Retracting force: The strap tension shall be measured at the point of contact with (but just clear of) the dummy while the strap is being retracted at the approximate rate of 0.6 m/min.

26.4.6.1.2 Locking test for retractors: the locking must have occurred when the deceleration of the vehicle reaches 0.45g (0.85g in the case of type 4N retractors) the amount of strap movement which may occur before the retractor locks shall not exceed 50 mm.

26.4.6.1.3 Locking test for extraction of strap: measured in the direction of the extraction of the strap.

26.4.6.1.4 Locking angle test: the retractor shall be mounted on a horizontal table and the table tilted with a speed not

The official directions are written in Chinese, this English edition is for your reference only.

exceeding 2 degrees per second until locking has occurred.

26.4.6.1.5 Durability test: It shall then satisfactorily complete a further 5,000 cycles after the sample has performed the following tests.

26.4.6.1.5.1 Test for withdrawing and retracting: The strap shall be withdrawn and allowed to retract until 40,000 cycles have been completed at a rate of not more than 30 cycles per minute. In the case of emergency locking retractors, a snatch to lock the retractor shall be introduced at each fifth cycle.

26.4.6.1.5.2 Corrosion test: The retractor shall then be subjected to the corrosion test given in paragraph 26.4.1 above. The strap shall be unwound to full length less  $300 \pm 3$  mm.

26.4.6.1.5.3 Dust resistance test: After corrosion test, the retractor shall then be subjected to the dust test. The retractor shall be positioned in a test chamber. The test chamber shall contain dust. A length of 500 mm of the strap shall be extracted from the retractor and kept extracted, except that it shall be subjected to 10 complete cycles of retraction and withdrawal within one or two minutes after each agitation of the dust. For a period of five hours, the dust shall be agitated every 20 minutes for five seconds by compressed air free of oil and moisture. The retractor shall be positioned in a test chamber as described in Fig. 7.

If the assembly incorporates a tension-reducing device, the above tests shall be conducted on condition that the tension-reducing device is in operation mode and in non-operation mode.

26.4.6.2 Automatically-locking retractor:

26.4.6.2.1 Retracting forces: The strap tension shall be measured at the point of contact with (but just clear of) the dummy while the strap is being retracted at the approximate rate of 0.6 m/min.

26.4.6.2.2 Automatically locking test: The strap of a safety-belt assembly equipped with an automatically locking retractor moves between locking positions of the retractor.

26.4.6.2.3 Durability test: It shall then satisfactorily complete a further 5,000 cycles after the sample has performed the following tests.

26.4.6.2.3.1 Test for withdrawing and retracting: The strap shall be withdrawn and allowed to retract until 5,000 cycles have been completed at a rate of not more than 30 cycles per minute.

26.4.6.2.3.2 Corrosion test: The retractor shall then be subjected to the corrosion test given in paragraph 26.4.1 above. The strap shall be unwound to full length less  $300 \pm 3$  mm.

26.4.6.2.3.3 Dust resistance test: After corrosion test, the retractor shall then be subjected to the dust test. The retractor shall be positioned in a test chamber. The test chamber shall contain dust. A length of 500 mm of the strap

shall be extracted from the retractor and kept extracted. For a period of five hours, the dust shall be agitated every 20 minutes for five seconds by compressed air free of oil and moisture.

26.4.7 Dynamic test:

26.4.7.1 Manikin: Total mass including correction weights is 75kg (nominal weight).

26.4.7.2 The buckle shall be capable of withstanding repeated operation and, prior to the dynamic test. The belts shall have undergone the corrosion test described in paragraph 26.4.1, after which the buckles shall be subjected to 500 additional opening and closing cycles under normal conditions of use · if it adopt gunpowder way of pre-loading device · the device shall following 26.4.7.7 stipulation that place it two hours ◦

26.4.7.3 In the case of a safety-belt with tension-reducing device, it shall be subjected to a durability test with such a device in operation mode before a dynamic test. The dynamic test shall then be conducted with the tension-reducing device in operation mode.

26.4.7.4 A board 25 mm thick shall be placed between the back of the manikin and the seat back. The belt shall be firmly adjusted to the manikin. The board shall then be removed so that the entire length of its back is in contact with the seat back.

26.4.7.5 Deceleration or acceleration devices, the applicant shall choose to use one of the two following devices:

26.4.7.5.1 The trolley shall be so propelled that at the moment of impact its free running speed is 50 km/h +/- 1 km/h and the manikin remains stable. The stopping distance of the trolley shall be 40 cm +/- 5 cm. The trolley shall remain horizontal throughout deceleration. The deceleration of the trolley shall be achieved by using the apparatus This apparatus shall comply with the performance hereafter specified:

- (a) The deceleration curve of the trolley, weighted with inert mass to produce a total mass of 455 kg +/- 20 kg for safety-belts tests and 910 kg +/- 40 kg for restraining systems tests where the nominal mass of the trolley and vehicle structure is 800 kg,
- (b) The deceleration curve of the trolley, must remain within the hatched area of the graph in Fig 8 or Fig 9.
- (c) If necessary, the nominal mass of the trolley and attached vehicle structure can be increased by increments of 200 kg, in which case, an additional inert mass of 28 kg per increment shall be added.
- (d) In no case shall the total mass of the trolley and vehicle structure and inert masses differ from the nominal value for calibration tests by more than +/- 40 kg.
- (e) During calibration of the stopping device, the speed of the trolley shall be 50 km/h +/- 1 km/h and the stopping distance shall be of 40 cm +/- 2 cm.

26.4.7.5.2 Acceleration test device :The trolley shall be so propelled that its total velocity change  $\Delta V$  is  $51 \text{ km/h} \begin{smallmatrix} +2 \\ -0 \end{smallmatrix} \text{ km/h}$ .

The trolley shall remain horizontal during the acceleration. The acceleration of the trolley shall be achieved by using the apparatus complying with the performance hereafter specified:

- (a) The acceleration curve of the trolley, weighted with inert mass, must remain within the hatched area of the graph in Fig 8 or Fig 9, and stay above the segment defined by the coordinates 10g, 5 ms and 20g, 10 ms.
- (b) The start of the impact (T0) is defined, according to ISO 17 373 (2005) for a level of acceleration of 0.5g.
- (c) In no case shall the total mass of the trolley and vehicle structure and inert masses differ from the nominal value for calibration tests by more than +/- 40 kg.
- (d) During calibration of the acceleration test device, trolley's total velocity change  $\Delta V$  shall be  $51 \text{ km/h} \pm_0 \text{ km/h}$ .
- (e) Despite the fulfilment of the above requirements, the technical service shall use a mass of trolley (equipped with its seat) greater than 380 kg.

26.4.7.6 Safety-belts with retractors shall have been subjected either to the tests described in paragraph 26.4.6.1.5.2. or to those described in paragraph 26.4.6.2.3.2. If, however, a retractor has already been subjected to the corrosion test in accordance with the corrosion test., above, this test need not be repeated.

26.4.7.7 The pre-loading device may be separated from the safety-belt to be tested and kept for 24 hours at a temperature of 60 degrees +/- 5 degrees C. The temperature shall then be raised to 100 degrees +/- 5 degrees C for two hours. Subsequently it shall be kept for 24 hours at a temperature of -30 degrees +/- 5 degrees C . After being removed from conditioning, the device shall warm up to ambient temperature.

26.4.7.8 In the case of a safety-belt or restraint system forming part of an assembly for which type approval is requested as a restraint system, the safety-belt shall be mounted either as defined in paragraph 26.4.7 or on the part of the vehicle structure to which the restraint system is normally fitted and this part shall be rigidly attached to the test trolley in the way prescribed in paragraphs 26.4.7.2 to 26.4.7.5.

## 26.5 Requirements

26.5.1 Corrosion test: Neither signs of deterioration likely to impair the proper functioning of the device nor any significant corrosion shall be visible to the unaided eye.

26.5.2 Micro-slip test: The strap slip shall not exceed 25 mm for each sample of adjusting device and the sum of shifts for all the adjusting devices shall not exceed 40 mm.

26.5.3 Strap test:

26.5.3.1 The initial breaking strength test: In the case of the two straps samples, the breaking load of the strap shall be not less than 14,700 N. The difference between the breaking loads of the two samples shall not exceed 10 per cent of the greater of the breaking loads measured.

26.5.3.2 Width test: The width of the strap under load of 9800 N + 1000 - 0 N shall be not less than 46 mm. This dimension shall be measured according to the test prescribed in paragraph 26.4.3.2., stopping the machine at the above mentioned load.

- 26.5.3.3 Light-conditioning test: In the case of the two strap samples conditioned, the breaking load of the strap shall be not less than 75 per cent of average of the loads determined in the test and not less than 14,700 N.
- 26.5.3.4 Abrasion conditioning test: In the case of the two strap samples conditioned, the breaking load of the strap shall be not less than 75 per cent of average of the loads determined in the test and not less than 14,700 N.
- 26.5.3.5 Cold conditioning test: In the case of the two strap samples conditioned, the breaking load of the strap shall be not less than 75 per cent of average of the loads determined in the test and not less than 14,700 N.
- 26.5.3.6 Heat conditioning test: In the case of the two strap samples conditioned, the breaking load of the strap shall be not less than 75 per cent of average of the loads determined in the test and not less than 14,700 N.
- 26.5.3.7 Exposure-to-water test: In the case of the two strap samples conditioned, the breaking load of the strap shall be not less than 75 per cent of average of the loads determined in the test and not less than 14,700 N.
- 26.5.4 Test of belt assembly components incorporating rigid parts:
  - 26.5.4.1 Strength test: They must not break or become detached under the tension set up by the prescribed load.
  - 26.5.4.2 Operation-force test: The force required to operate any manually adjusting device shall not exceed 50 N.
- 26.5.5 Buckle test:
  - 26.5.5.1 Durability test: no damage or erosion found at the tested buckle.
  - 26.5.5.2 Buckle-opening test: It shall not be possible to release the buckle inadvertently, accidentally or with a force of less than 10 N.  
The force required to open the buckle after the dynamic test shall not exceed 60 N.
- 26.5.6 Tests for safety-belt with retractors:
  - 26.5.6.1 The emergency locking retractors:
    - 26.5.6.1.1 Retracting force: If the retractor is part of a lap belt (two-point type safety-belt), the retracting force of the strap shall be not less than 7 N. If the retractor is part of an upper torso restraint (three-point type safety-belt), the retracting force of the strap shall be not less than 1 N and not more than 7 N, except for a belt equipped with a tension-reducing device, in which case the minimum retracting force may be reduced to 0.5 N only when such a device is in operation mode.
    - 26.5.6.1.2 Locking test for retractors: The amount of strap movement which may occur before the retractor locks shall not exceed 50 mm.
    - 26.5.6.1.3 Locking test for extraction of strap: For values of acceleration of the strap measured in the direction of the extraction of the strap of less than 0.8 g (1.0g in the case of type 4N retractors), locking must not occur during the 50 mm of strap movement. For values of acceleration of the strap measured in the direction of the extraction of the strap of more than 2.0 g, locking must occur during the 50 mm of strap movement.

The official directions are written in Chinese, this English edition is for your reference only.



- 26.5.6.1.4 Locking angle test: It must not lock when its sensing device is tilted 12 degrees or less in any direction from the installation position specified by its manufacturer. It shall lock when its sensing device is tilted by more than 27 degrees (40 degrees in the case of type 4N retractors) in any direction from the installation position specified by its manufacturer.
- 26.5.6.1.5 Durability test: After the above tests, the retractor shall operate correctly and still meet the requirements above.
- 26.5.6.2 Automatically-locking retractor:
  - 26.5.6.2.1 Retracting force: If the retractor is part of a lap belt (two-point type safety-belt), the retracting force of the strap shall be not less than 7 N. If the retractor is part of an upper torso restraint (three-point type safety-belt), the retracting force of the strap shall be not less than 1 N and not more than 7 N.
  - 26.5.6.2.2 Automatically-locking test: The strap of a safety-belt assembly equipped with an automatically locking retractor shall not move more than 30 mm between locking positions of the retractor.
  - 26.5.6.2.3 Durability test: After the above tests, the retractor shall operate correctly and still meet the requirements above.
- 26.5.7 Dynamic performance test:
  - 26.5.7.1 After impact, the belt assembly or restraint system and its rigid parts shall be inspected visually, without opening the buckle, to determine whether there has been any failure or breakage.
  - 26.5.7.2 During the test, it should observe the manikin's actions and measure the forwarding movement at the waist and shoulder portions each.
    - 26.5.7.2.1 Lap belts (two-point type safety-belt): the forward displacement of the manikin shall be between 80 and 200 mm at pelvic level.
    - 26.5.7.2.2 Diagonal belts (three-point type safety-belt: the movement at the waist portion should be within the range of 80-200 mm, and the movement at the shoulder portion should be within the range of 100-400 mm.
      - 26.5.7.2.2.1 In the case of a safety-belt intended to be used in an outboard front seating position protected by an airbag in front of it, the displacement of the chest reference point may exceed that specified in paragraph 26.5.7.2.2 if its speed at this value does not exceed 24 km/h.
  - 26.5.7.3 In the case of safety-belt with a preloading device the minimum displacement specified in paragraph 26.5.7.2 below may be reduced by half. For the purpose of this test, the preloading device shall be in operation.

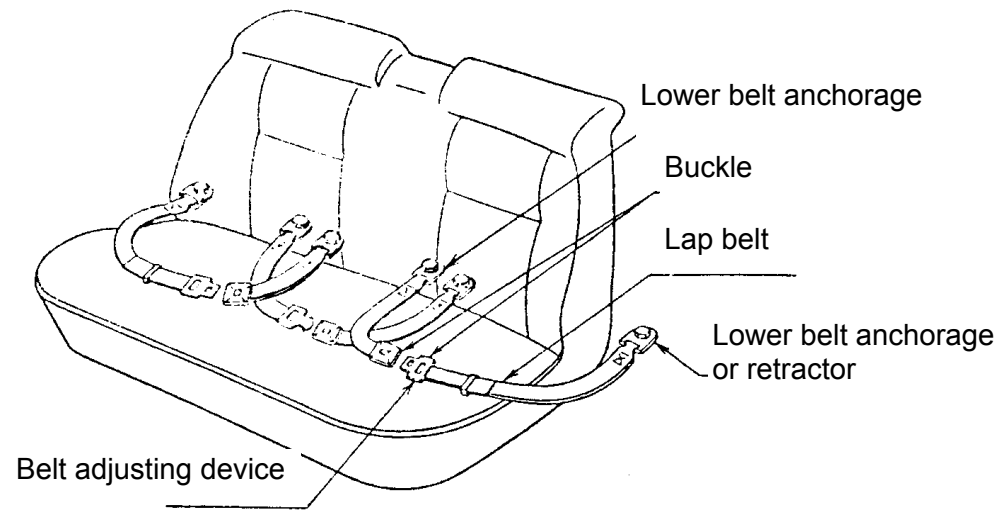

Fig 1. Schematic sketch of two-point type safety-belt

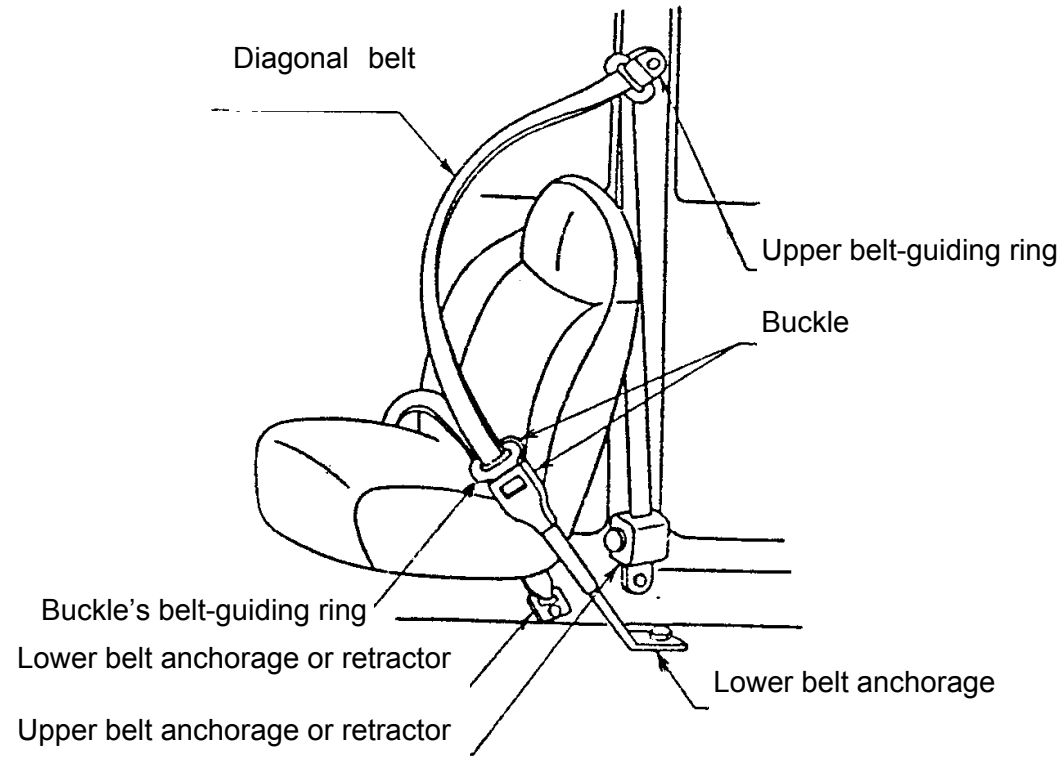

Fig 2. Schematic sketch of three-point type safety-belt

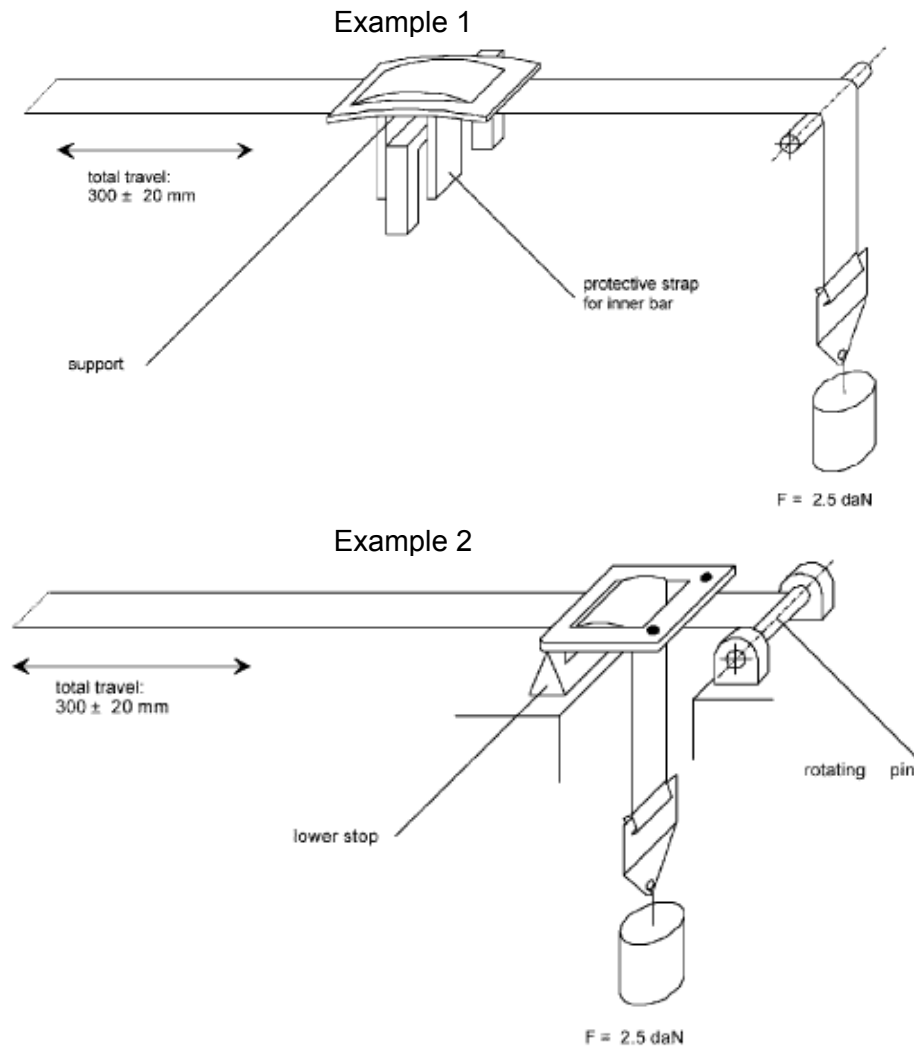
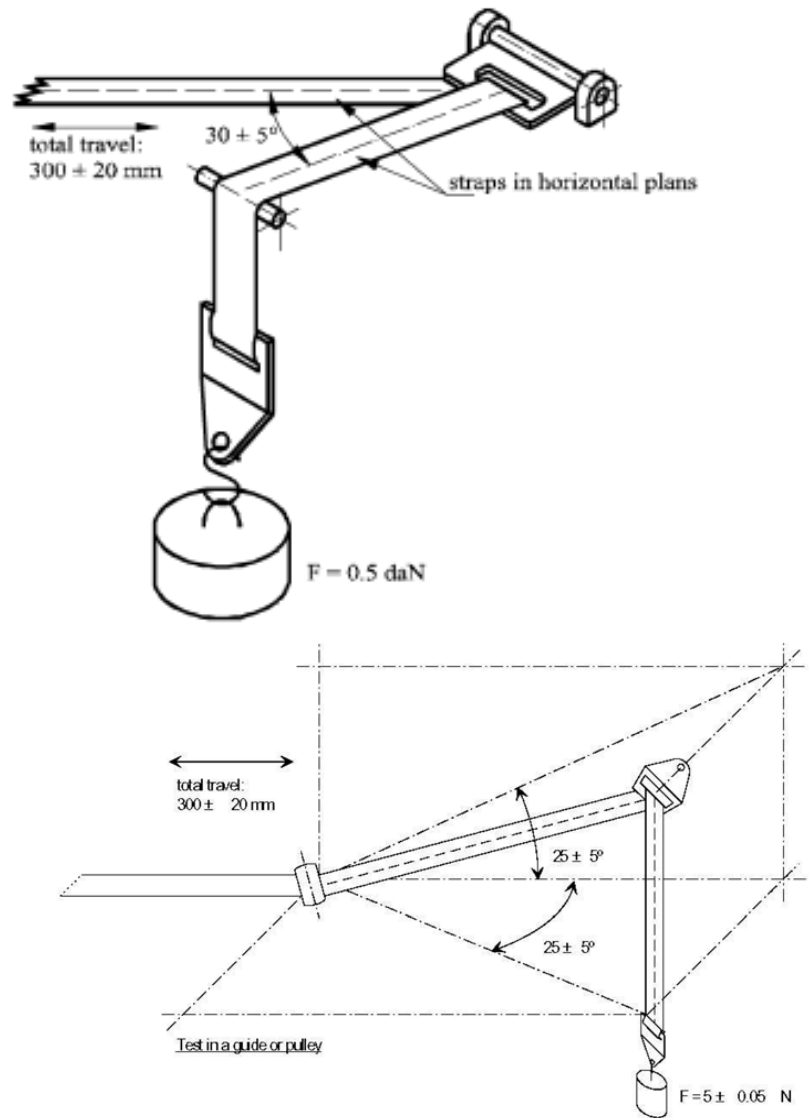

Fig 3. Type-1 abrasion

The official directions are written in Chinese, this English edition is for your reference only.



All dimensions in mm

Fig 4. Type-2 abrasion

The official directions are written in Chinese, this English edition is for your reference only.

Total travel: 300 +/- 20 mm

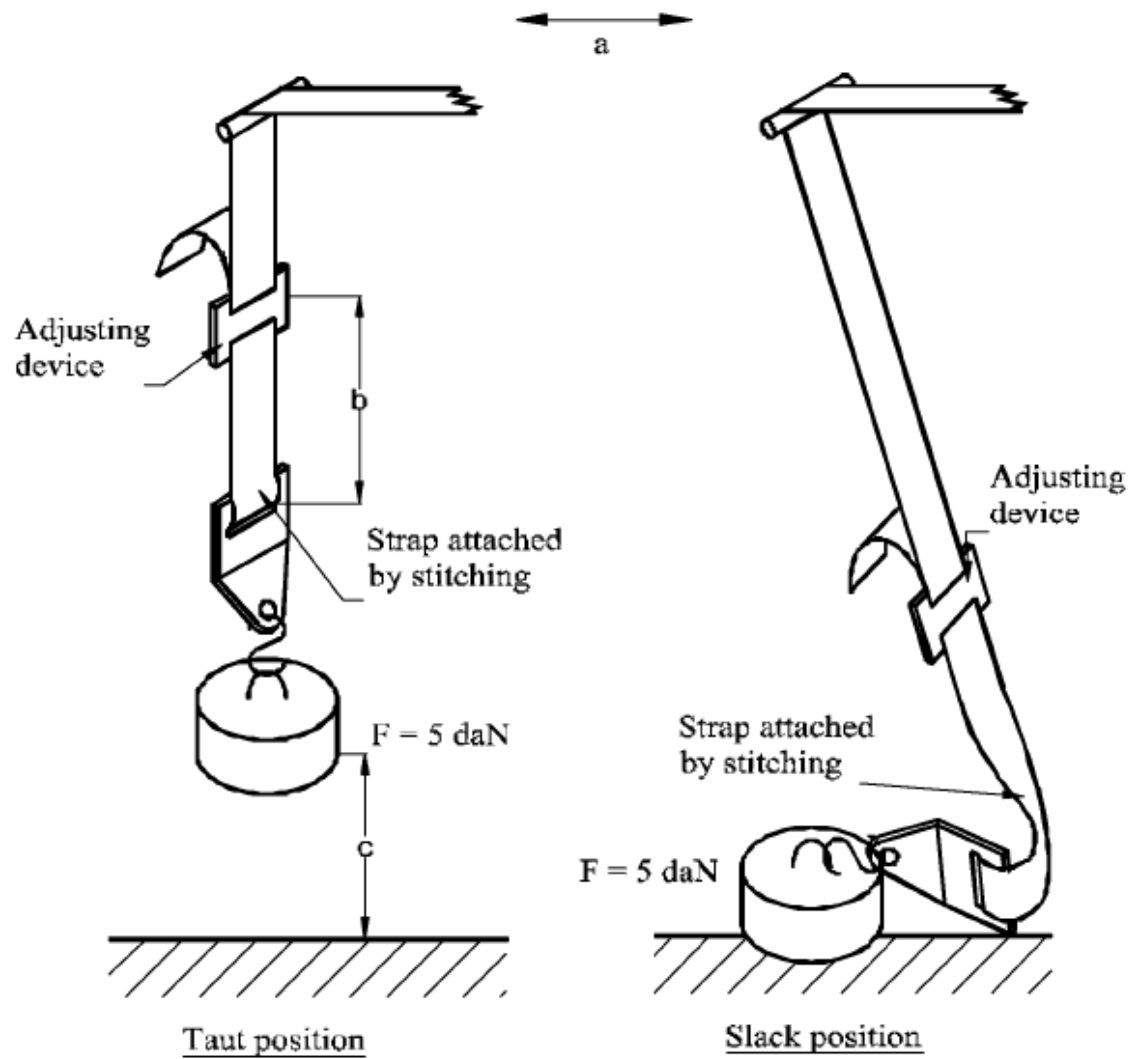

Fig 5. Type-3 abrasion-test procedure and micro-slip test

The official directions are written in Chinese, this English edition is for your reference only.

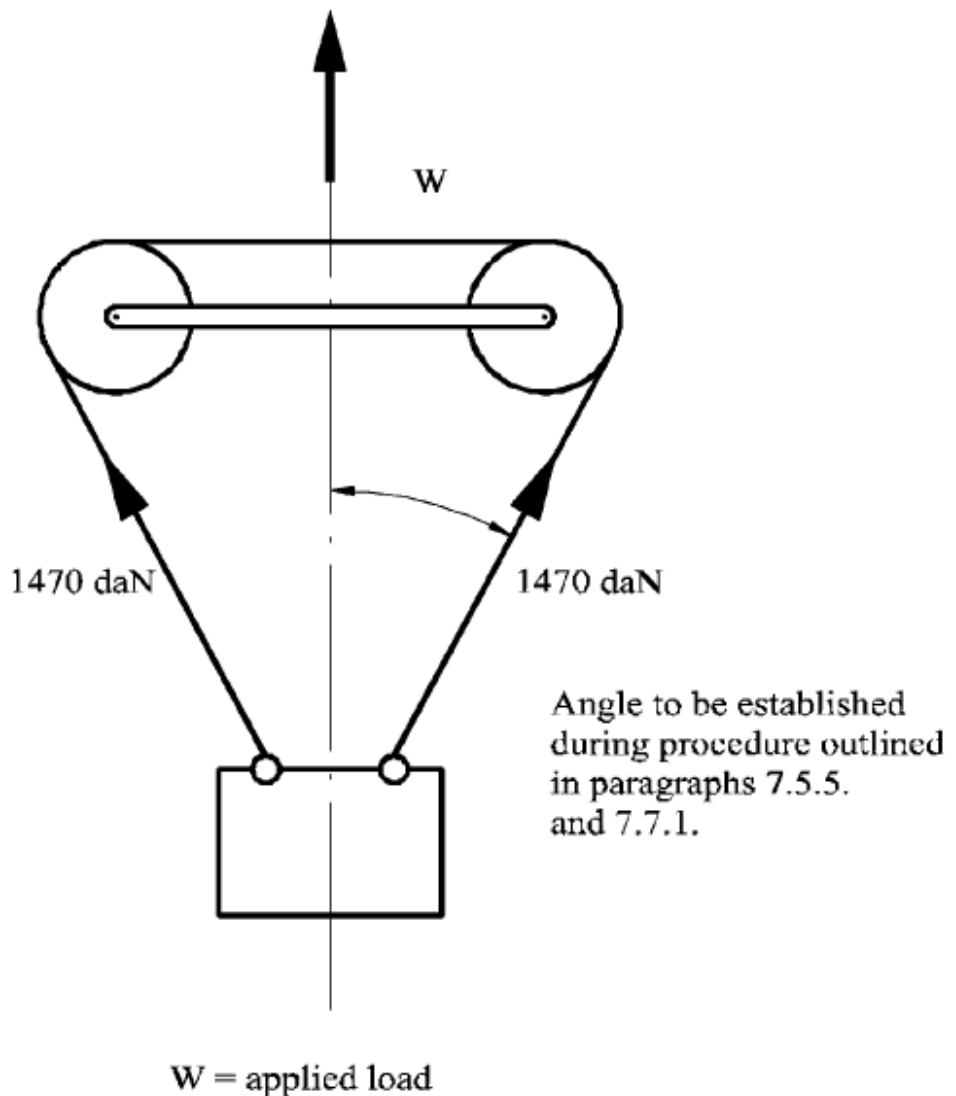

Fig 6. Dual buckle test

The official directions are written in Chinese, this English edition is for your reference only.

**Definition of the different curves**

Time (ms)	Acceleration (g)	
	Low corridor	High corridor
0	-	20
10	0	-
10	15	-
15	20	-
18	-	32
25	26	-
45	26	-
55	20	-
60	0	32
80	-	0

Chart 1: Definition of the different curves



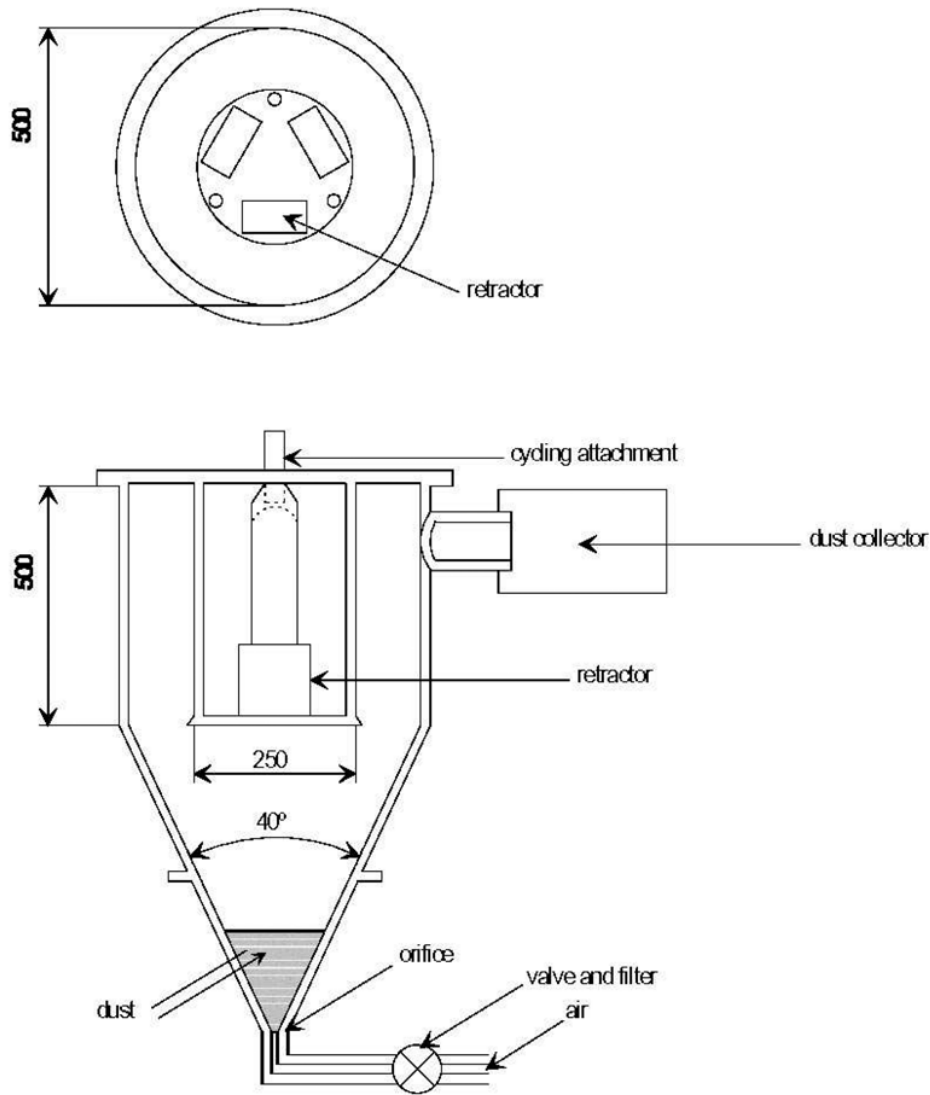
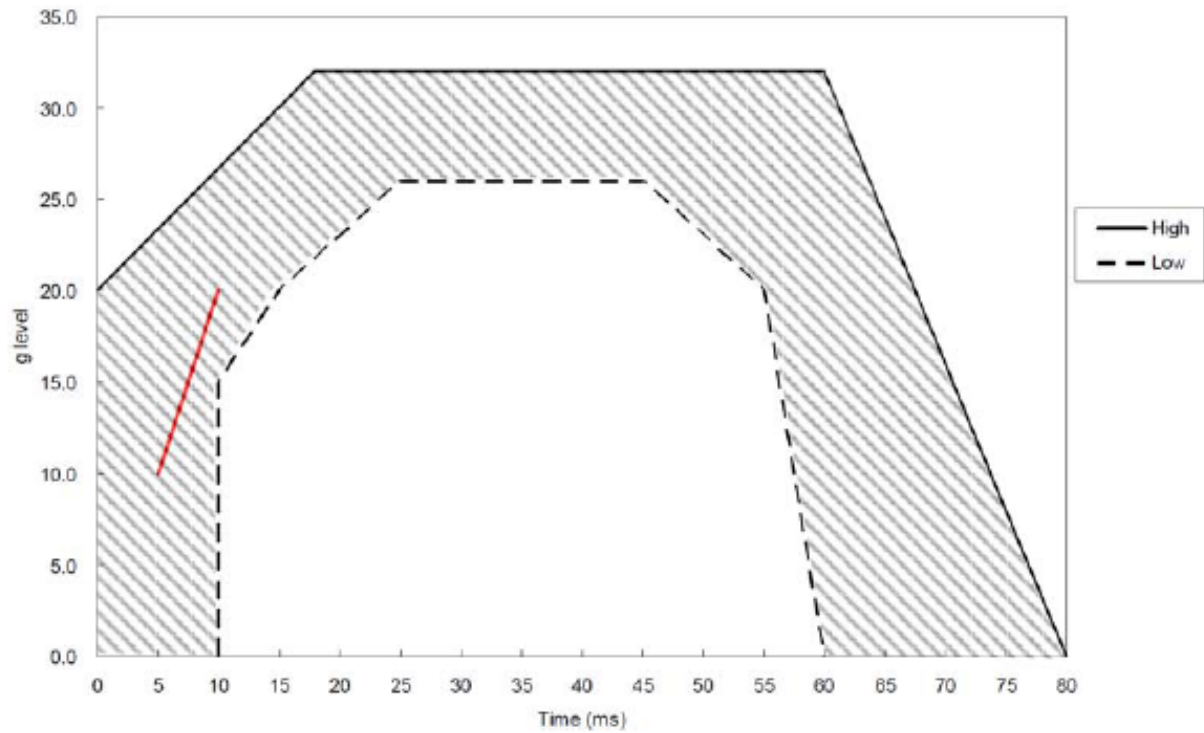

Fig. 7. The retractor shall be positioned in a test chamber

The official directions are written in Chinese, this English edition is for your reference only.



The additional segment applies only for the acceleration sled

Fig 8. Description of curve of trolley's acceleration/deceleration as a function of time

The official directions are written in Chinese, this English edition is for your reference only.

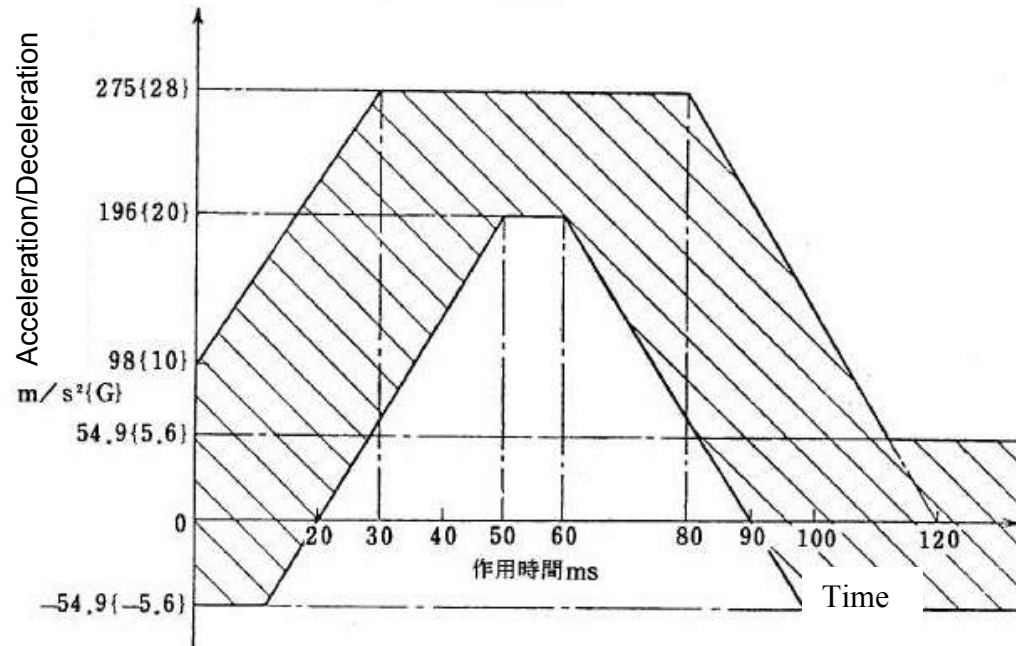

Fig 9. Description of curve of trolley's acceleration/deceleration as a function of time