

34 Front position lamps

Refer to: R7 02-S15/C1, R50 00-S14

34.1 Effective date and Scope:

- 34.1.1 From 2006/7/1, the new vehicle variants of category symbols M, N and O, and from 2008/7/1 all vehicle variants of category symbols M, N and O, the front position lamp shall comply with this regulation and shall be use bulbs that is conform with "Filament lamps" of this Direction.
- 34.1.2 From 2009/1/1, the new vehicle variants of category symbols L1 and L3, and from 2011/1/1 all vehicle variants of category symbols L1, L2, L3 and L5, the front position lamp shall comply with this regulation and shall be use bulbs that is conform with "Filament lamps" of this Direction.
- 34.1.3 For the vehicles imported by authorities, organizations, schools or individuals for self-use only may be exempt from regulation of "front position lamps".
- 34.1.4 For the low volume type safety approval, maximum 20% deviation of the levels of intensity standard of this test is allowed, and if the light source is LED, it can omit the failure conditions test.

34.2 Front position lamps : The lamp is used to indicate the presence and the width of vehicle when viewed from the front.

34.3 Front position lamps shall according to suitable variants and range are of principle :

34.3.1 Brand

34.3.2 The characteristics of the optical system (levels of intensity, light distribution angles, category of filament lamp, light source module, etc.) , however , if bulbs or filter's color is change that it doesn't mean to change the variants.

34.4 Photometric measurements : .

34.4.1 Within the field of light distribution schematically shown as a grid in Figure 1, the light pattern should be substantially uniform.

34.4.2 In each direction corresponding to the points in the light distribution be not less than the product of the minimum specified in Table1 by the percentage specified in the said figure of the direction in question. In no direction within the space from which the light-signalling device is visible, exceed the maximum specified in Table.

34.4.2.1 For an assembly of two or more lamps the total intensity shall not exceed the maximum value prescribed for a single lamp.

34.4.2.2 When an assembly of two or more lamps having the same function is deemed to be a single lamp, it shall comply with the requirements for:

34.4.2.2.1 Maximum intensity if all lamps together are lit;

34.4.2.2.2 Minimum intensity if one lamp has failed.

34.4.2.3 In case of failure of a single lamp containing more than one light source the following provisions shall apply:

The official directions are written in Chinese, this English edition is for your reference only.

- 34.4.2.3.1 A group of light sources, wired so that the failure of any one of them causes all of them to stop emitting light, shall be considered to be one light source.
- 34.4.2.3.2 The lamp shall comply with the minimum intensity required when any one light source has failed (refer to figure 1). However, for lamps designed for only two light sources, 50 per cent of the minimum intensity in the axis of reference of the lamp shall be considered sufficient, provided that a note in the communication form states that the lamp is only for use on a vehicle fitted with an operating tell-tale which indicates when any one of these two light sources has failed;
- 34.4.3 Moreover, throughout the fields defined in the diagrams, the intensity of the light emitted must be not less than 0.05 cd. In the case where a device is intended to be installed at a mounting height of equal to or less than 750 mm above the ground, the photometric intensity is verified only up to an angle of 5 degrees downwards.
- 34.4.4 Angles required for light distribution in space of the lamps:
 - 34.4.4.1 In the case of front position lamps used on the vehicles of category symbols M, N and O, horizontal angles are shown in Figure 2 (H plane: "horizontal plane going through the reference centre of the lamp").The minimum vertical angles of light distribution in space are 15 degrees above and 15 degrees below the horizontal except for lamps with a permissible mounting height less than 750 mm above the ground, for which they are 15 degrees above and 5 degrees below the horizontal.
 - 34.4.4.2 In the case of front position lamps used on the vehicles of category symbols L1 and L3:
 - 34.4.4.2.1 For a pair of lamps : Horizontal angles are shown in Figure 2. Vertical angles are $+15^{\circ} / -10^{\circ}$.
 - 34.4.4.2.2 For a single lamp : Horizontal angles are shown in Figure 3. Vertical angles are $+15^{\circ} / -10^{\circ}$.
- 34.4.5 If the front position lamp incorporates one or more infrared radiation generators, the photometric and colour requirements for this front position lamp shall be met with and without the operation of the infrared radiation generator(s).
- 34.4.6 In the case of front position lamps used on the vehicles of category symbols L1 and L3:
 - 34.4.6.1 In the case of a single lamp containing more than one light source:
 - (a) Minimum intensity if one lamp has failed.
 - (b) For an assembly of two or more lamps the total intensity shall not exceed the maximum value prescribed for a single lamp, multiplied by 1.4.
 - (c) A group of light sources, wired so that the failure of any one of them causes all of them to stop emitting light, shall be considered to be one light source.
- 34.5 Trichromatic coordinate: The colour of the light emitted inside the field shall be white defined in "The installation of lighting and light-signaling devices" of "Directions". Outside this field, no sharp variation of colour shall be observed. These requirements shall also apply within the range of variable luminous intensity produced in Figure 1 below. These requirements shall also apply within the range of variable

luminous intensity produced by testing conditions. However, for lamps equipped with non-replaceable light sources (filament lamps and other), the colorimetric characteristics should be verified with the light sources present in the lamp.

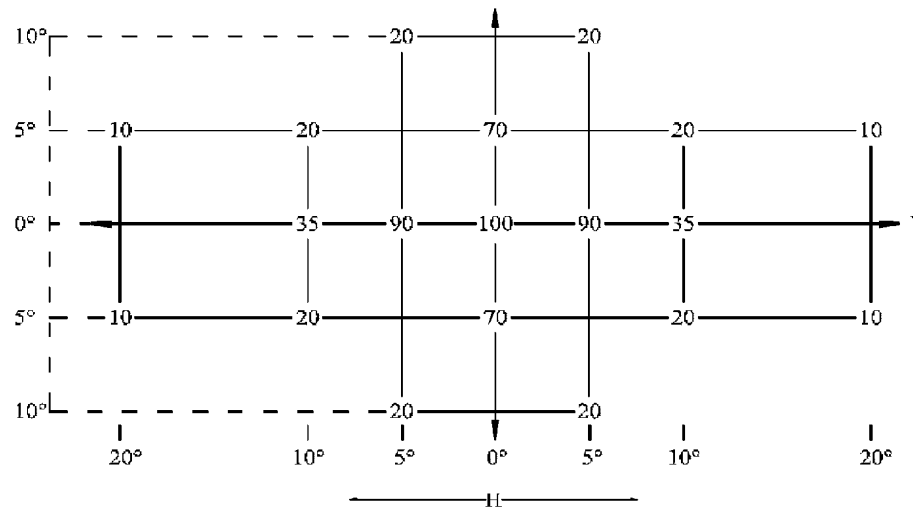

Figure 1. Light distribution

34.6 Comply with this lamps of Regulation that is equal comply with “End-outline marker lamps”.

Table 1. In the reference axis, the light emitted shall be at least equal to the minimum values and not exceed the maximum values specified below :

Category	Light intensity (Candelas)	Minimum light intensity	Maximum value when used as	
			Single lamp	Lamp (single) marked “D”
Front position lamp A		4	140	70
Front position lamp incorporated in headlamp		4	140	---
Category	Light intensity (Candelas)	Minimum light intensity	Maximum light intensity	
Front position lamp for category symbols L		4	60	

Front position lamp incorporated in headlamp for category symbols L	4	100
---	---	-----

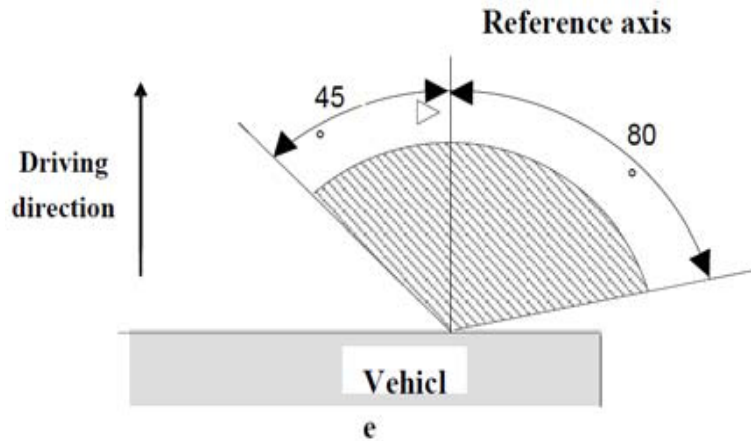

Figure 2. Horizontal angles for Front position lamp fitted to M/N/O vehicles with a pair of lamps.
 On and above the H plane for all lamps.
 Under the H plane for lamps intended for M2, M3, N2 or N3 category vehicles.

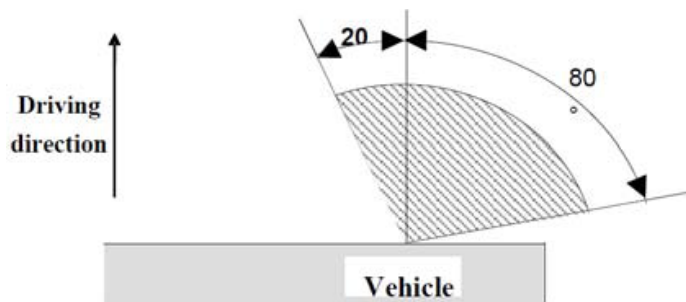

Figure 2-1 Front position lamps, Under the H plane for M1 or N1 category vehicles.

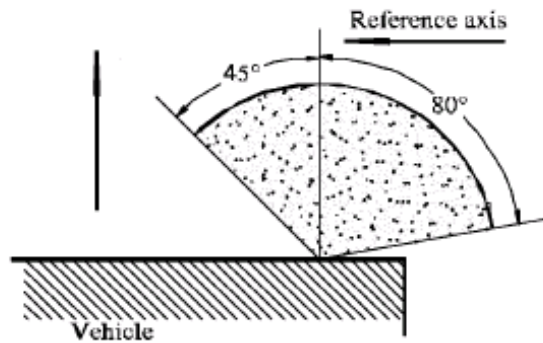

Figure 2-2 Horizontal angles for Front position lamp fitted to L vehicles with a pair of lamps.

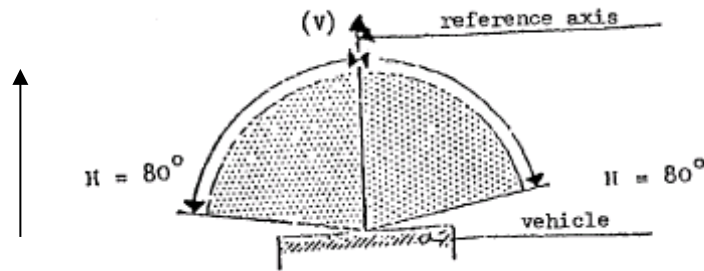

Figure 3. Horizontal angles for Single-lamp front position lamp fitted to L vehicles

34.7 In the case of replaceable filament lamp(s):

34.7.1 Any category or categories of filament lamp(s) approved according to “Directions” of “Filament lamps” may be used, it’s shall concern about relevant special restriction.

34.7.2 The design of the device shall be such that the filament lamp can be fixed in no other position but the correct one.

34.7.3 The filament lamp holder shall conform to the characteristics given in IEC Publication 60061.

34.8 In the case of light source modules, it shall be checked that:

34.8.1 The design of the light source module(s) shall be such as:

34.8.1.1 that each light source module can only be fitted in no other position than the designated and correct one and can only be removed with the use of tool(s);

34.8.1.2 If there are more than one light source module used in the housing for a device, light source modules having different

The official directions are written in Chinese, this English edition is for your reference only.

characteristics can not be interchanged within the same lamp housing.

34.8.2 The light source module(s) shall be tamperproof.

34.8.3 A light source module shall be so designed that regardless of the use of tool(s), it shall not be mechanically interchangeable with any replaceable approved light source.

34.9 Measuring condition for each test:

34.9.1 Vehicles of category symbols M, N and O :

34.9.1.1 Test voltage :

34.9.1.1.1 In the case of a lamp equipped with non-replaceable light sources (filament lamps and other), at 6.75 V, 13.5 V or 28.0 V respectively.

34.9.1.1.2 In case of a lamp with replaceable light source, if not supplied by an electronic light source control gear or a variable intensity control, with an uncolored or colored standard filament lamp of the category prescribed for the device, supplied with the voltage necessary to produce the reference luminous flux required for that category of filament lamp.

when equipped with filament lamps at 6.75 V, 13.5 V or 28.0 V, the luminous intensity values produced shall be corrected. The correction factor is the ratio between the reference luminous flux and the mean value of the luminous flux found at the voltage applied (6.75 V, 13.5 V or 28.0 V). The actual luminous fluxes of each filament lamp used shall not deviate more than +/- 5 per cent from the mean value. Alternatively a standard filament lamp may be used in turn, in each of the individual positions, operated at its reference flux, the individual measurements in each position being added together.

34.9.1.1.3 In the case of a system that uses an electronic light source control gear or a variable intensity control, being part of the lamp 6/ applying at the input terminals of the lamp the voltage declared by the manufacturer or, if not indicated, 6.75 V, 13.5 V or 28.0 V respectively.

34.9.1.1.4 In the case of a system that uses an electronic light source control gear or a variable intensity control, not being part of the lamp the voltage declared by the manufacturer shall be applied to the input terminals of the lamp.

34.9.1.2 However, in the case of light sources operated by a variable intensity control to obtain variable luminous intensity, photometric measurements shall be performed according to the applicant's description.

34.9.1.3 The technical service shall require from the manufacturer the light source control gear or a variable intensity control needed to supply the light source and the applicable functions.

34.9.1.4 The limits of the apparent surface in the direction of the reference axis of a light-signaling device shall be determined.

34.9.2 Vehicles of category symbols L :

34.9.2.1 Test voltage :

- 34.9.2.1.1 In case of a lamp with replaceable light source, if not supplied by an electronic light source control gear with an uncoloured or coloured standard filament lamp of the category prescribed for the device, at the necessary voltage to produce the reference luminous flux required for that category of filament lamp;
when equipped with filament lamps at 6.75 V, 13.5 V or 28.0 V, the luminous intensity values produced shall be corrected. The correction factor is the ratio between the reference luminous flux and the mean value of the luminous flux found at the voltage applied (6.75 V, 13.5 V or 28.0 V). The actual luminous fluxes of each filament lamp used shall not deviate more than +/- 5 per cent from the mean value. Alternatively a standard filament lamp may be used in turn, in each of the individual positions, operated at its reference flux, the individual measurements in each position being added together.
- 34.9.2.1.2 In the case of a lamp equipped with non-replaceable light sources (filament lamps and other), at 6.75 V, 13.5 V or 28.0 V respectively;
- 34.9.2.1.3 In the case of a system that uses an electronic light source control gear being part of the lamp³ applying at the input terminals of the lamp the voltage declared by the manufacturer or, if not indicated, 6.75 V, 13.5 V or 28.0 V, respectively;
- 34.9.2.1.4 In the case of a system that uses an electronic light source control gear not being part of the lamp, the voltage declared by the manufacturer shall be applied to the input terminals of the lamp.
- 34.9.2.2 The test laboratory shall require from the manufacturer the light source control gear needed to supply the light source and the applicable functions.
- 34.9.2.3 The limits of the apparent surface in the direction of the reference axis of a light signalling device shall be determined.