

## 64 Electric safety requirements for battery electric vehicles ( From 2014/1/1 )

Refer to: R100 01

### 64.1 Effective Date and Scope:

64.1.1 From 2014/1/1, the new variant of categories M and N electric vehicles with a maximum design speed exceeding 25 km/h and from 2016/1/1, all variant of categories M and N electric vehicles with a maximum design speed exceeding 25 km/h shall comply with this regulation.

### 64.2 Definitions

64.2.1 "Active driving possible mode" means the vehicle mode when application of pressure to the accelerator pedal (or activation of an equivalent control) or release of the brake system will cause the electric power train to move the vehicle.

64.2.2 "Barrier" means the part providing protection against direct contact to the live parts from any direction of access.

64.2.3 "Conductive connection" means the connection using connectors to an external power supply when the RESS is charged.

64.2.4 "Coupling system for charging the rechargeable energy storage system (RESS)" means the electrical circuit used for charging the RESS from an external electric power supply including the vehicle inlet.

64.2.5 "Direct contact" means the contact of persons with live parts.

64.2.6 "Electrical chassis" means a set made of conductive parts electrically linked together, whose potential is taken as reference.

64.2.7 "Electrical circuit" means an assembly of connected live parts which is designed be electrically energized in normal operation.

64.2.8 "Electric energy conversion system" means a system that generates and provides electric energy for electric propulsion.

64.2.9 "Electric power train" means the electrical circuit which includes the traction motor(s), and may include the RESS, the electric energy conversion system, the electronic converters, the associated wiring harness and connectors, and the coupling system for charging the RESS.

64.2.10 "Electronic converter" means a device capable of controlling and/or converting electric power for electric propulsion.

64.2.11 "Enclosure" means the part enclosing the internal units and providing protection against direct contact from any direction of access.

64.2.12 "Exposed conductive part" means the conductive part which can be touched under the provisions of the protection degree IPXXB, and which becomes electrically energized under isolation failure conditions.

64.2.13 "External electric power supply" means an alternating current (AC) or direct current (DC) electric power supply outside of the vehicle.

64.2.14 "High Voltage" means the classification of an electric component or circuit, if its working voltage is  $> 60$  V and  $\square 1500$  V DC or  $> 30$  V and  $\square 1000$  V AC root mean square (rms).

64.2.15 "High voltage bus" means the electrical circuit, including the coupling system for charging the RESS that operates on high voltage.

64.2.16 "Indirect contact" means the contact of persons or livestock with exposed conductive parts.

The official directions are written in Chinese, this English edition is for your reference only.

- 64.2.17 "Live parts" means the conductive part(s) intended to be electrically energized in normal use.
- 64.2.18 "Luggage compartment" means the space in the vehicle for luggage accommodation, bounded by the roof, hood, floor, side walls, as well as by the barrier and enclosure provided for protecting the power train from direct contact with live parts, being separated from the passenger compartment by the front bulkhead or the rear bulk head.
- 64.2.19 "On-board isolation resistance monitoring system" means the device which monitors the isolation resistance between the high voltage buses and the electrical chassis.
- 64.2.20 "Open type traction battery" means a liquid type battery requiring refilling with water and generating hydrogen gas released to the atmosphere.
- 64.2.21 "Passenger compartment" means the space for occupant accommodation, bounded by the roof, floor, side walls, doors, window glass, front bulkhead and rear bulkhead, or rear gate, as well as by the barriers and enclosures provided for protecting the power train from direct contact with live parts.
- 64.2.22 "Protection degree" means the protection provided by a barrier/enclosure related to the contact with live parts by a test probe, such as a test finger (IPXXB) or a test wire (IPXXD), as defined in paragraph 64.5.
- 64.2.23 "Rechargeable energy storage system (RESS)" means the rechargeable energy storage system that provides electric energy for electric propulsion.
- 64.2.24 "Service disconnect" means the device for deactivation of the electrical circuit when conducting checks and services of the RESS, fuel cell stack, etc.
- 64.2.25 "Solid insulator" means the insulating coating of wiring harnesses provided in order to cover and protect the live parts against direct contact from any direction of access; covers for insulating the live parts of connectors, and varnish or paint for the purpose of insulation.
- 64.2.26 "Working voltage" means the highest value of an electrical circuit voltage root mean- square (rms), specified by the manufacturer, which may occur between any conductive parts in open circuit conditions or under normal operating conditions. If the electrical circuit is divided by galvanic isolation, the working voltage is defined for each divided circuit, respectively.

64.3 The applicable type and scope principles for battery electric vehicles are as below :

- 64.3.1 The same vehicle category..
- 64.3.2 The same brand and vehicle type.
- 64.3.3 The same installation of the electric power train and the galvanically connected high voltage bus.
- 64.3.4 The same nature and type of electric power train and the galvanically connected high voltage components.

64.4 Tests and requirements :

64.4.1 Protection against Electrical Shock

The official directions are written in Chinese, this English edition is for your reference only.

These electrical safety requirements apply to high voltage buses under conditions where they are not connected to external high voltage power supplies.

#### 64.4.1.1 Protection against direct contact

The protection against direct contact with live parts shall comply with paragraphs 64.4.1.1.1. and 64.4.1.1.2. These protections (solid insulator, barrier, enclosure, etc.) shall not be able to be opened, disassembled or removed without the use of tools.

64.4.1.1.1 For protection of live parts inside the passenger compartment or luggage compartment, the protection degree IPXXD shall be provided.

64.4.1.1.2 For protection of live parts in areas other than the passenger compartment or luggage compartment, the protection degree IPXXB shall be satisfied.

#### 64.4.1.1.3 Connectors

Connectors (including vehicle inlet) are deemed to meet this requirement if:

(a) they comply with 64.4.1.1.1. and 64.4.1.1.2. when separated without the use of tools, or

(b) they are located underneath the floor and are provided with a locking mechanism, or

(c) they are provided with a locking mechanism and other components shall be removed with the use of tools in order to separate the connector, or

(d) the voltage of the live parts becomes equal or below DC 60V or equal or below AC 30V (rms) within 1 second after the connector is separated.

#### 64.4.1.1.4 Service disconnect

For a service disconnect which can be opened, disassembled or removed without tools, it is acceptable if protection degree IPXXB is satisfied under a condition where it is opened, disassembled or removed without tools.

#### 64.4.1.1.5 Vehicle Markings

64.4.1.1.5.1 The symbol shown in Figure 1 shall appear on or near the RESS.

The symbol background shall be yellow, the bordering and the arrow shall be black.



The official directions are written in Chinese, this E

reference only.

Figure 1 — Marking of high voltage equipment

64.4.1.1.5.2 The symbol shall also be visible on enclosures and barriers, which, when removed expose live parts of high voltage circuits. This provision is optional to any connector for high voltage buses. This provision shall not apply to any of the following cases :

- (a) where barriers or enclosures cannot be physically accessed disassembled, opened or removed, unless other vehicle components are removed with the use of tools.
- (b) where barriers or enclosures are located underneath the vehicle floor.

64.4.1.1.5.3 Cables for high voltage buses which are not located within enclosures shall be identified by having an outer covering with the colour orange.

#### 64.4.1.2 Protection against indirect contact

64.4.1.2.1 For protection against electrical shock which could arise from indirect contact, the exposed conductive parts, such as the conductive barrier and enclosure, shall be galvanically connected securely to the electrical chassis by connection with electrical wire or ground cable, or by welding, or by connection using bolts, etc. so that no dangerous potentials are produced.

64.4.1.2.2 The resistance between all exposed conductive parts and the electrical chassis shall be lower than 0.1 ohm when there is current flow of at least 0.2 amperes. This requirement is satisfied if the galvanic connection has been established by welding.

64.4.1.2.3 In the case of motor vehicles which are intended to be connected to the grounded external electric power supply through the conductive connection, a device to enable the galvanical connection of the electrical chassis to the earth ground shall be provided.

The device should enable connection to the earth ground before exterior voltage is applied to the vehicle and retain the connection until after the exterior voltage is removed from the vehicle.

Compliance to this requirement may be demonstrated either by using the connector specified by the car manufacturer, or by analysis.

#### 64.4.1.3 Isolation resistance

64.4.1.3.1 Electric power train consisting of separate direct current- or alternating current buses

If AC high voltage buses and DC high voltage buses are galvanically isolated from each other, isolation resistance between the high voltage bus and the electrical chassis shall have a minimum value of 100 ohms/volt of the working voltage for DC buses, and a minimum value of 500 ohms/volt of the working voltage for AC buses.

The measurement shall be conducted according to paragraph 64.6 "isolation resistance measurement method".

#### 64.4.1.3.2 Electric power train consisting of combined DC- and AC-buses

If AC high voltage buses and DC high voltage buses are galvanically connected isolation resistance between the high voltage bus and the electrical chassis shall have a minimum value of 500 ohms/volt of the working voltage.

However, if all AC high voltage buses are protected by one of the 2 following measures, isolation resistance between the high voltage bus and the electrical chassis shall have a minimum value of 100 ohms/volt of the working voltage.

(a) Double or more layers of solid insulators, barriers or enclosures that meet the requirement in paragraph 64.4.1.1. independently, for example wiring harness

(b) Mechanically robust protections that have sufficient durability over vehicle service life such as motor housings, electronic converter cases or connectors.

The isolation resistance between the high voltage bus and the electrical chassis may be demonstrated by calculation, measurement or a combination of both.

The measurement shall be conducted according to paragraph 64.6 "Isolation Resistance Measurement Method".

#### 64.4.1.3.3 Fuel cell vehicles

If the minimum isolation resistance requirement cannot be maintained, then protection shall be achieved by any of the following:

(a) Double or more layers of solid insulators, barriers or enclosures that meet the requirement in paragraph 64.4.1.1 independently.

(b) On-board isolation resistance monitoring system together with a warning to the driver if the isolation resistance drops below the minimum required value. The isolation resistance between the high voltage bus of the coupling system for charging the RESS, which is not energized besides during charging the RESS, and the electrical chassis need not to be monitored. The function of the on-board isolation resistance monitoring system shall be confirmed as described in paragraph 64.7.

#### 64.4.1.3.4 Isolation resistance requirement for the coupling system for charging the RESS

For the vehicle inlet intended to be conductively connected to the grounded external AC power supply and the electrical circuit that is galvanically connected to the vehicle inlet during charging of the RESS, the isolation resistance between the high voltage bus and the electrical chassis shall be at least 1M ohms when the charger coupler is disconnected. During the measurement, the traction battery may be disconnected.

### 64.4.2 RESS

#### 64.4.2.1 Protection against excessive current

The RESS shall not overheat.

If the RESS is subject to overheating due to excessive current, it shall be equipped with a protective device such as fuses, circuit breakers or main contactors.

However, the requirement may not apply if the manufacturer supplies data that ensures overheating from excessive current is prevented without the protective device.

#### 64.4.2.2 Accumulation of gas

Places for containing open type traction battery that may produce hydrogen gas shall be provided with a ventilation fan or a ventilation duct to prevent the accumulation of hydrogen gas.

#### 64.4.3 Functional safety requirements

At least a momentary indication shall be given to the driver when the vehicle is in "active driving possible mode".

However, this provision does not apply under conditions where an internal combustion engine provides directly or indirectly the vehicle's propulsion power.

When leaving the vehicle, the driver shall be informed by a signal (e.g. optical or audible signal) if the vehicle is still in the active driving possible mode.

If the on-board RESS can be externally charged by the user, vehicle movement by its own propulsion system shall be impossible as long as the connector of the external electric power supply is physically connected to the vehicle inlet.

This requirement shall be demonstrated by using the connector specified by the car manufacturer.

The state of the drive direction control unit shall be identified to the driver.

#### 64.5 Protection against direct contacts of parts under voltage

##### 64.5.1 Access probes

Access probes to verify the protection of persons against access to live parts are given in table 1.

##### 64.5.2 Test conditions

The access probe is pushed against any openings of the enclosure with the force specified in table 1. If it partly or fully penetrates, it is placed in every possible position, but in no case shall the stop face fully penetrate through the opening.

Internal barriers are considered part of the enclosure.

A low-voltage supply (of not less than 40 V and not more than 50 V) in series with a suitable lamp should be connected, if necessary, between the probe and live parts inside the barrier or enclosure.

The signal-circuit method should also be applied to the moving live parts of high voltage equipment.

Internal moving parts may be operated slowly, where this is possible.

**Table 1 - Access probes for the tests for protection of persons against access to hazardous parts**

First numeral	Addit. letter	Access probe (Dimensions in mm)	Test force
2	B	<p><b>Jointed test finger</b></p> <p>See Fig.1 for full dimensions</p> <p>Insulating material</p> <p>Jointed test finger (Metal)</p> <p>Stop face (Ø 50 x 20)</p> <p>Ø 12</p> <p>80</p>	10 N ± 10 %
4, 5, 6	D	<p><b>Test wire 1.0 mm diameter, 100 mm long</b></p> <p>Test wire 1.0 mm diameter, 100 mm long</p> <p>Ø 10</p> <p>Approx. 100</p> <p>Sphere 35 ± 0.2</p> <p>100 ± 0.2</p> <p>Ø 1.0</p> <p>+0.05</p> <p>0</p> <p>Handle (Insulating material)</p> <p>Stop face (Insulating material)</p> <p>Rigid test wire (Metal)</p> <p>Edges free from burrs</p>	1 N ± 10 %

The official directions are written in Chinese, this Engl

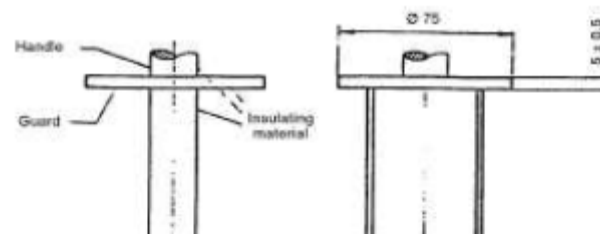

s for battery electric vehicles

Figure 2 - Jointed test finger

#### 64.5.3 Acceptance conditions

The access probe shall not touch live parts.

If this requirement is verified by a signal circuit between the probe and live parts, the lamp shall not light.

In the case of the test for IPXXB, the jointed test finger may penetrate to its 80 mm length, but the stop face (diameter 50 mm x 20 mm) shall not pass through the opening. Starting from the straight position, both joints of the test finger shall be successively bent through an angle of up to 90 degree with respect to the axis of the adjoining section of the finger and shall be placed in every possible position.

In case of the tests for IPXXD, the access probe may penetrate to its full length, but the stop face shall not fully penetrate through the opening.

#### 64.6 Isolation resistance measurement method

##### 64.6.1 General

The isolation resistance for each high voltage bus of the vehicle shall be measured or shall be determined by calculation using

The official directions are written in Chinese, this English edition is for your reference only.



measurement values from each part or component unit of a high voltage bus (hereinafter referred to as the "divided measurement").

#### 64.6.2 Measurement Method

The isolation resistance measurement shall be conducted by selecting an appropriate measurement method from among those listed in Paragraphs 64.6.2.1 through 64.6.2.2., depending on the electrical charge of the live parts or the isolation resistance, etc.

The range of the electrical circuit to be measured shall be clarified in advance, using electrical circuit diagrams, etc.

Moreover, modification necessary for measuring the isolation resistance may be carried out, such as removal of the cover in order to reach the live parts, drawing of measurement lines, change in software, etc.

In cases where the measured values are not stable due to the operation of the on-board isolation resistance monitoring system, etc., necessary modification for conducting the measurement may be carried out, such as stopping of the operation of the device concerned or removing it. Furthermore, when the device is removed, it shall be proven, using drawings, etc., that it will not change the isolation resistance between the live parts and the electrical chassis. Utmost care shall be exercised as to short circuit, electric shock, etc., for this confirmation might require direct operations of the high-voltage circuit.

##### 64.6.2.1 Measurement method using DC voltage from off-vehicle sources

###### 64.6.2.1.1 Measurement instrument

An isolation resistance test instrument capable of applying a DC voltage higher than the working voltage of the high voltage bus shall be used.

###### 64.6.2.1.2 Measurement method

An insulator resistance test instrument shall be connected between the live parts and the electrical chassis. Then, the isolation resistance shall be measured by applying a DC voltage at least half of the working voltage of the high voltage bus. If the system has several voltage ranges (e.g. because of boost converter) in galvanically connected circuit and some of the components cannot withstand the working voltage of the entire circuit, the isolation resistance between those components and the electrical chassis can be measured separately by applying at least half of their own working voltage with those component disconnected.

##### 64.6.2.2 Measurement method using the vehicle's own RESS as DC voltage source

###### 64.6.2.2.1 Test vehicle conditions

The high voltage-bus shall be energized by the vehicle's own RESS and/or energy conversion system and the voltage level of the RESS and/or energy conversion system throughout the test shall be at least the nominal operating voltage as specified by the vehicle manufacturer.

###### 64.6.2.2.2 Measurement instrument

The voltmeter used in this test shall measure DC values and shall have an internal resistance of at least 10 MΩ.

###### 64.6.2.2.3 Measurement method

The official directions are written in Chinese, this English edition is for your reference only.

#### 64.6.2.2.3.1 First step

The voltage is measured as shown in Figure 1 and the high voltage Bus voltage ( $V_b$ ) is recorded.  $V_b$  shall be equal to or greater than the nominal operating voltage of the RESS and/or energy conversion system as specified by the vehicle manufacturer.

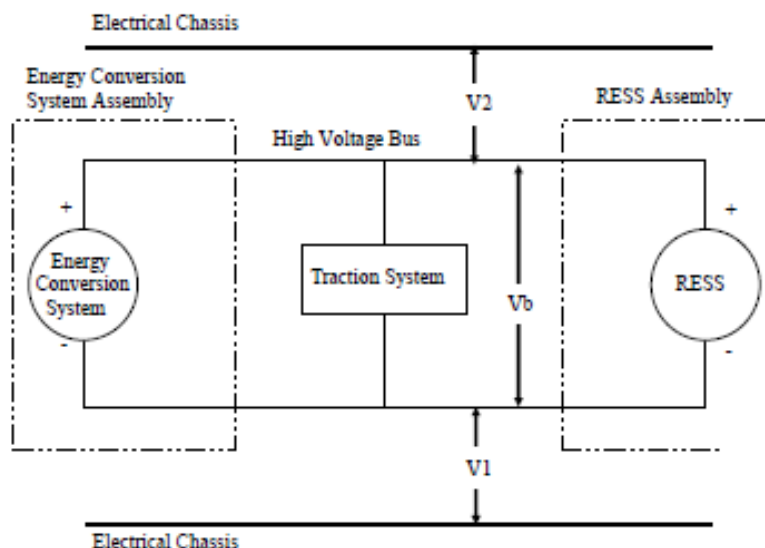

#### 64.6.2.2.3.2 Second step

Measure and record the voltage ( $V_1$ ) between the negative side of the high voltage bus and the electrical chassis (see Figure 3):

#### 64.6.2.2.3.3 Third step

Measure and record the voltage ( $V_2$ ) between the positive side of the high voltage bus and the electrical chassis (see Figure 3):

#### 64.6.2.2.3.4 Fourth step

If  $V_1$  is greater than or equal to  $V_2$ , insert a standard known resistance ( $R_o$ ) between the negative side of the high voltage bus and the electrical chassis. With  $R_o$  installed, measure the voltage ( $V_1'$ ) between the negative side of the high voltage bus and the electrical chassis (see Figure 4).

Calculate the electrical isolation ( $R_i$ ) according to the following formula:

$$R_i = R_o \cdot (V_b / V_1' - V_b / V_1) \text{ or } R_i = R_o \cdot V_b \cdot (1 / V_1' - 1 / V_1)$$

The official directions are written in Chinese, this English edition is for your reference only.

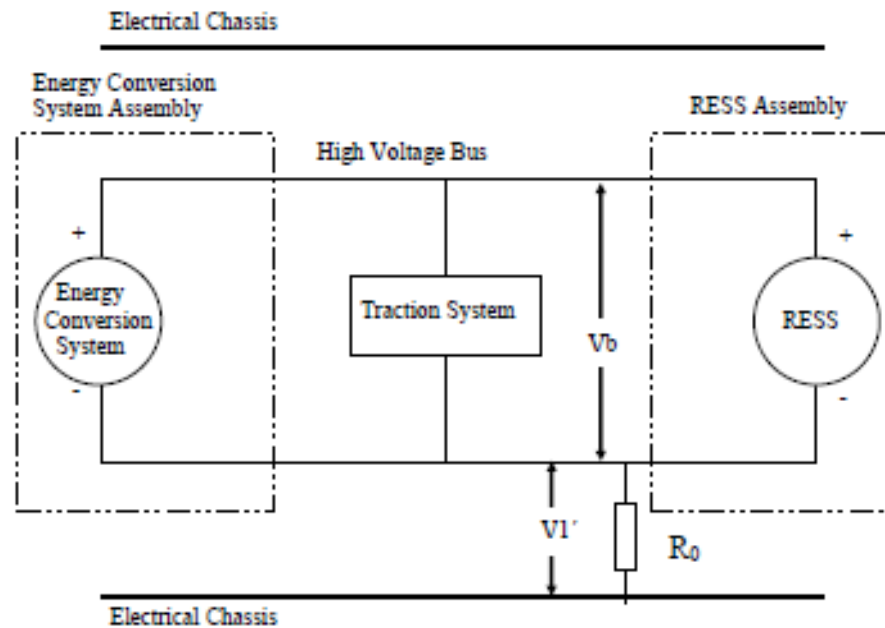

If  $V_2$  is greater than  $V_1$ , insert a standard known resistance ( $R_0$ ) between the positive side of the high voltage bus and the electrical chassis. With  $R_0$  installed, measure the voltage ( $V_2'$ ) between the positive side of the high voltage bus and the electrical chassis. (See Figure 3). Calculate the electrical isolation ( $R_i$ ) according to the formula shown. Divide this electrical isolation value (in ohms) by the nominal operating voltage of the high voltage bus (in volts).

Calculate the electrical isolation ( $R_i$ ) according to the following formula:

$$R_i = R_0 \cdot (V_b / V_2' - V_b / V_2) \text{ or } R_i = R_0 \cdot V_b \cdot (1 / V_2' - 1 / V_2)$$

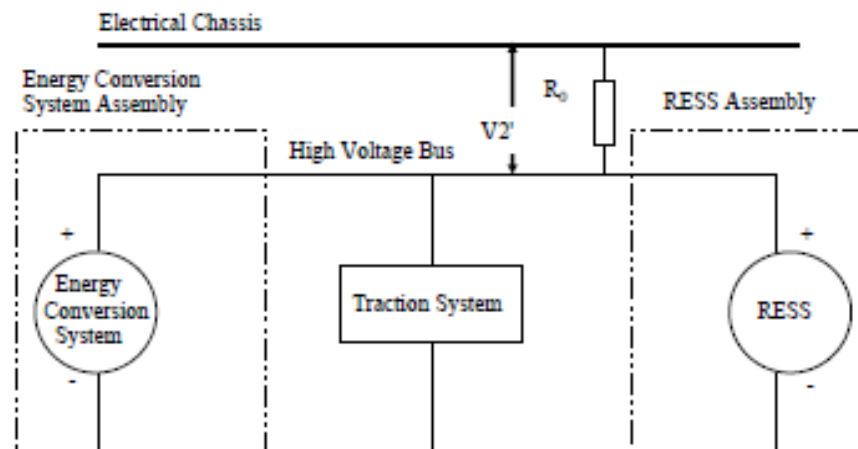

The official directions are written in Chinese, th

requirements for battery electric vehicles

Figure 5: Measurement of  $V_2'$

64.6.2.2.3.5 Fifth step

The electrical isolation value  $R_i$  (in ohms) divided by the working voltage of the high voltage bus (in volts) results in the isolation resistance (in ohms/volt).

NOTE 1: The standard known resistance  $R_o$  (in ohms) should be the value of the minimum required isolation resistance (in ohms/V) multiplied by the working voltage of the vehicle plus/minus 20 per cent (in volts).  $R_o$  is not required to be precisely this value since the equations are valid for any  $R_o$ ; however, a  $R_o$  value in this range should provide good resolution for the voltage measurements.

64.7 Confirmation method for functions of on-board isolation resistance monitoring system

The function of the on-board isolation resistance monitoring system shall be confirmed by the following method.

Insert a resistor that does not cause the isolation resistance between the terminal being monitored and the electrical chassis to drop below the minimum required isolation resistance value. The warning shall be activated.